

Фрезер СМТ за дърво профилен за подравняване, с лагер ф 12.7x25.4/70.7 мм, ф 8 мм, 7/8/906

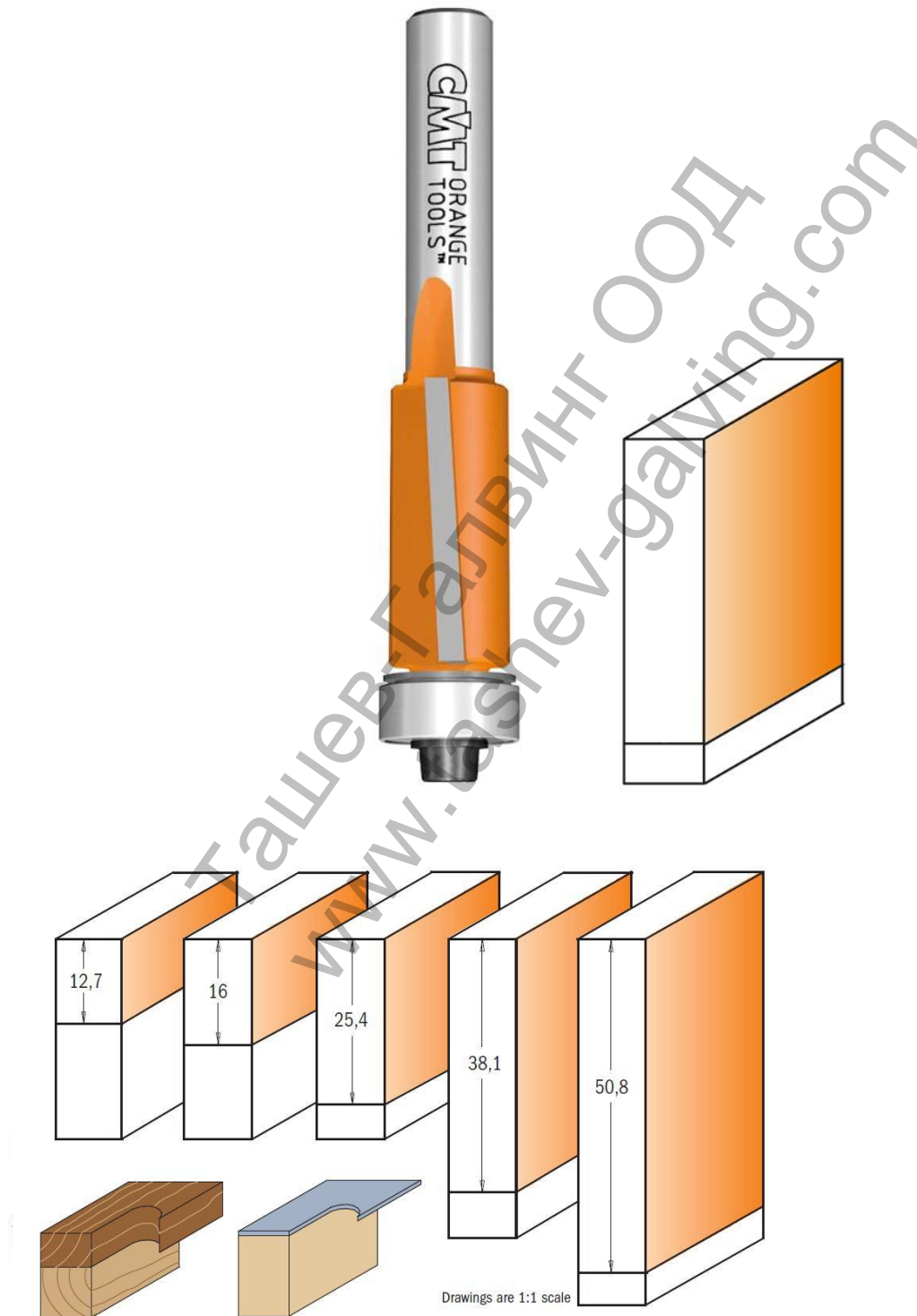

We have designed a series of truly indispensable bits available in a wide range of sizes for your woodworking needs and

your most difficult projects. For precision work on laminates or quick template work with excellent finishing.

Shop tips: these bits are excellent for making through mortises. Use a straight bit (#711.130.11) to groove the through mortise area, then use the drill bit (#517.130.31) to bore a through hole at the end of the groove. Turn the workpiece over to end the mortise. Use the flush trim bit with a cutting length slightly longer than the fillet, following the groove made on the opposite side of the workpiece with the ball bearing guide.



Tungsten carbide
tipped



Solid tungsten carbide



Two cutting edges



Right-hand rotation



Tool with bearing

• HWM

I mm	D mm	L mm	ORDER NO. S=Ø6mm	ORDER NO. S=Ø6,35mm	ORDER NO. S=Ø8mm	ORDER NO. S=Ø12mm	ORDER NO. S=Ø12,7mm
•25,4	6,35	63,5	706.064.11	806.064.11			
12,7	9,5	55,5	706.096.11	806.096.11	906.096.11		
12,7	12,7	57,8	706.128.11	806.128.11	906.128.11		
12,7	12,7	70,6				906.628.11	806.628.11
16	19	57,1	706.190.11		906.190.11		
25,4	9,5	68,2	706.095.11	806.095.11	906.095.11		
25,4	12,7	70,7	706.127.11	806.127.11	906.127.11		
25,4	12,7	86,6				906.627.11	806.627.11
38,1	12,7	94				906.629.11	806.629.11
50,8	12,7	103,7				906.630.11	806.630.11

Продукт: [Фрезер CMT за дърво профилен за подравняване, с лагер ф 12.7x25.4/70.7 мм, ф 8 мм, 7/8/906](#)

Категория: [Консумативи за фрези и обертфрези](#)

Бранд: [CMT](#)

Категория бранд: [Фрезер CMT](#)

Ташев-Галвини
www.tashev-galvini.com